

Welcome to Spartan Electric  
Company

**A. PRODUCTS**

- SWITCHES AND RECEPTACLES
- LIGHTING FIXTURES
- SMOKE DETECTORS
- PANEL BOX AND CIRCUIT BREAKERS
- CEILING FAN OUTLETS

**B. WARRANTY SERVICE**

- WHAT IS COVERED
- WHAT IS NOT COVERED

**C. TYPICAL SERVICE ISSUES**

- EXAMPLES AND CORRECT STEPS TO TAKE

**D. ADDITIONAL SERVICES AND PRODUCTS**

- ONQ UPGRADES
- SATELLITE AND COMPUTER WIRING
- WHOLE HOUSE LIGHTING CONTROL
- GENERATOR
- CEILING FANS
- INTERCOM OPTIONS
- WHOLE HOUSE SURGE PROTECTION
- MISCELLANEOUS OPTIONS

***NEW***

***HOMEOWNER***

***INFORMATION***

***MANUAL***



**SPARTAN ELECTRIC  
COMPANY**

**10097 Tyler Place, Suite 9  
Ijamsville, MD 21754  
301-831-8300 Fax 301-831-1210  
Toll Free 1-800-935-0065**

New Homeowner,

Congratulations on the purchase of your new home. This interactive manual has been designed to provide you with information regarding the electrical products installed by *Spartan Electric Company* in your home and the different services we offer post settlement.

While viewing this manual online you have the ability by clicking on the different company logos, and products shown to be taken to their respective web sites. More information can also be found anywhere the cursor changes from a grasping hand to a pointing finger. By clicking on these items you will be taken to additional information on the selected item either in this document or on the internet.

At *Spartan Electric Company* we pride ourselves on quality products and services, during all phases of construction, of your new home. From the initial walk-thru, to the installation of the last fixture, we strive to provide all homeowners with the assurance that the electrical design and installation in their new home will be completed to the highest standard.

To make your search for information easier, you can click on items in the table of contents to be taken to that area of the document. Remember though, not all homes have every product shown herein.

If you have any questions about any of the product you have in your home; or, if you want more information about add-on products, call our Service Manager toll free at (800) 935-0065.

Again, we would like to extend our congratulations and wishes that you have many happy years in your new home.

Best regards,

*Mr. Robby Robinson*

Mr. Robby Robinson  
President

# SWITCHES AND RECEPTACLES

All of the switches and receptacles used in your home are UL listed and come with a one-year warranty. We utilize two different manufacturers, Leviton and Pass & Seymour. By utilizing both Leviton and Pass & Seymour we can assure the highest quality devices have been installed in your new home.

## SWITCHES

There are various types of switches that have been installed in your home, as listed below:

Single pole switch – This type of switch operates the designated outlet from one location only.

Three-way switch – This switch is used in conjunction with another switch to have the ability to turn a designated outlet off and on from two different locations.

Four-way switch – This type of switch is used in conjunction with a set of 3 way switches in order to turn a designated outlet or light off and on from more than 2 locations.

You may also have dimmers installed in your home. These are switches that give you the ability to control the degree of lighting in a certain area by use of either a round knob or a slide button to increase and decrease volume of light.

## RECEPTACLES

These are the types of receptacles installed in your home:

Duplex receptacle – This type of receptacle is a standard two-outlet device that is used in most areas of the home.

GFCI receptacle – This type of receptacle is a ground fault circuit interrupter. This device is intended to eliminate shock hazards to people. This means that the outlet will automatically shut off if a surge in current is detected to prevent persons from being shocked. These are installed in various locations throughout your home. Kitchens, bathrooms, exterior and wet bar sink areas are the locations in which you will find either this type of outlet or an outlet protected by this type of circuit. These outlets will have two buttons on them. One of the buttons will read TEST the other RESET.

Once a month you should test the outlets by pressing the test button, at this point no power should come from the circuit. You can test this by plugging in a lamp and attempting to turn it on. After you have tested the outlet, press the reset button to turn the power back on. In some instances a hair dryer, curling iron, hot rollers or heaters can cause this outlet to “trip”; at this point the reset button will need to be reset.

Please keep in mind that the following items should not be plugged into a GFCI receptacle or an outlet protected by a GFCI circuit:

- Freezers
- Microwaves
- Refrigerator

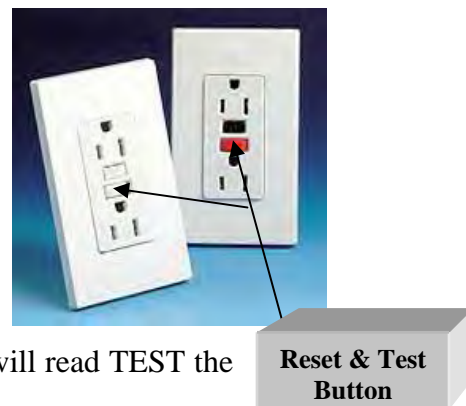

# LIGHTING FIXTURES

The lighting fixtures that have been installed in your home have been chosen because of the consistent quality the manufacturer has shown throughout the years. Progress Lighting, Seagull Lighting, Thomas Lighting and Lightolier are some of the brands we utilize. These fixtures come with a one-year warranty against defects.

To clean these fixtures please note the following:

- Brass finishes – DO NOT USE any type of abrasive cleaners on these surfaces. These are a brass finish with a protective coating that is removed when an abrasive cleaner is used. They are NOT solid brass. Use a clean cloth moistened with warm water only. You can use a quality automotive wax to protect against discoloration and spotting.
- Chrome finishes - DO NOT USE any type of abrasive cleaners on these surfaces. These are a chrome finish with a protective coating that is removed when an abrasive cleaner is used. Use a clean cloth moistened with warm water only. You can use a quality automotive wax to protect against discoloration and spotting.
- Other finishes - DO NOT USE any type of abrasive cleaners on these surfaces. Use a clean cloth moistened with warm water only. You can buff finish with a clean dry cloth to renew shine.

Because of Spartan Electric Company's years of experience and superb buying power, we can offer a complete line of lighting fixture upgrades such as:

- Chandeliers
- Tiffany lights
- Exterior and Landscape Lighting

# Smoke Detectors

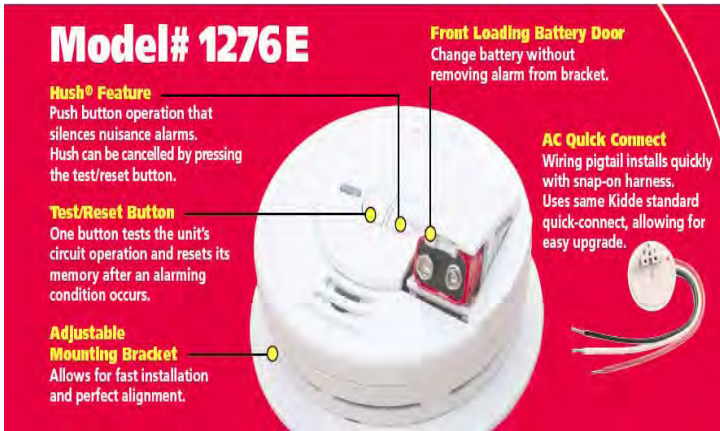

Spartan Electric has tested many different models of smoke detectors and has found that the Kidde Frynetics model#1276E is one of the most user friendly models on the market. It has the following features:

- 9 volt battery back-up
- Quick, plug-in connectors
- Test button to check all functions
- LED power and alarm indicators
- Ionization technology
- Interconnected with other smoke alarms in the home

Routine maintenance is required to keep your smoke detectors in good operating condition. Please note that the following maintenance procedures should be done on a regular basis:

1. Smoke detectors should be tested weekly.
2. Smoke detectors should be cleaned monthly. Use the wand end of your vacuum cleaner to remove any particles that may be inside of the detector. **DO NOT USE** water, cleaners or solvents of any type on the detector since they may damage the unit.
3. Batteries should be replaced when the detector “chirps” every 30 to 40 seconds. Make sure that a quality battery is installed.

## Nuisance Alarms

Nuisance alarms are when the detector sounds for no apparent reason. Some of the following things may be the cause of this:

- Steam from bathrooms
- Smoke from cooking areas
- Insects and bugs
- Fireplaces

Some solutions to these nuisance alarms are as follows:

- Use exhaust fans in the kitchen and bathrooms to reduce the smoke and steam from entering area where detectors are located.
- Monthly vacuuming removes dirt, dust, cobwebs and other particles that may get inside of the smoke detector and cause false alarms.
- If applicable, make sure dampers on fireplaces are open.

**NOTE:** When a smoke detector sounds, you can locate the originating alarm by the flashing red LED light. If you have repetitive nuisance alarms, this knowledge may come in handy to locate the smoke detector causing the problem.

## Battery Replacement

Press on the battery compartment on the unit. Remove the existing battery and replace with a new fresh battery, making sure that you replace it the same way it came out.

⚙️ As a rule of thumb you should replace the batteries when you change your clocks at daylight savings time.

# Load Centers and Circuit Breakers

Spartan Electric Company uses many quality manufacturers of Load Centers. Your home may have one of the following quality Load Centers:

**Square D** panel boxes and circuit breakers are the world's finest. Every detail focuses on more effective ways to ensure safety and to provide superior reliability. The industry leader in circuit protection is easily recognized by the industry's only trip indicator. The amber-colored VISI-TRIP® Indicator makes it easy to spot a tripped circuit breaker. The QO circuit breaker comes in a compact ¾ in. wide format for one-pole circuit breakers, helping minimize panel space and footprint. The Square D exclusive QWIK-OPEN® protection is standard on all 15 A and 20 A circuit breakers— trip reaction within 1/60<sup>th</sup> of a second. No other circuit breaker trips faster.



## QO® Circuit Breakers



The exclusive VISI-TRIP® Indicator provides clear and instant identification of a tripped circuit breaker. The highly visible indicator allows the homeowner to easily spot a tripped circuit, helps prevent callbacks, and reduces the chance that other circuits will be turned off accidentally.

**Cutler Hammer** Load Centers are enclosed assemblies used for power distribution and circuit protection in residential and light commercial applications.

- The assembly consists of a box, an interior assembly and a trim
- Incoming power is terminated at main lugs or a main circuit breaker
- Load circuit protection is provided by molded case circuit breakers
- Used on services providing no more than 240 VAC, and are available with bus rated from 40 to 600 amperes.



Load center covers are available as surface, flush or combination.



## Miniature Circuit Breakers

A specific type of circuit breaker, used to switch and protect the lowest common distribution voltage in an electrical system. Generally used in a Load Center, panelboard, or similar device. Eaton's Cutler-Hammer line of miniature circuit breakers are available with a wide selection of accessories, including ARC Fault interrupters, and can be custom

modified to meet special application requirements.

- ARC Fault Interrupters (AFCI) are a new type of breaker that when installed will monitor the circuit for any shorts. It is much more sensitive than other standard breakers. An example of their protection would be having a nail or screw driven into the sheathing of a piece of wire, touching the hot conductor and the neutral or ground wires. It may not be enough to short the circuit, but enough to cause a situation that causes a continuous arcing because of the penetration. An AFCI would detect the arcing where a standard breaker would not. Without the AFCI, this type of situation, if left unnoticed, could cause a hazardous situation that you may not be aware of until it is too late. At this time the National Electrical Code (NEC) requires bedrooms to be protected by this type of breaker.

# Ceiling Fan Rough-ins

In some rooms you might see a blank cover plate, on the ceiling, in the center of the room. This box is no mistake. This box contains the wiring, should you decide at a later date, to install a ceiling fan or light.

You may also notice in rooms that have the blank plate over the ceiling outlet, there are switches that appear to control nothing. These switches would be for the future installation of a ceiling fan/light.

By installing these boxes and switches during construction, you will save a large installation fee for an after-market installation.

The ceiling outlet will contain three (3) wires plus a green or bare ground wire. The white wire is the neutral and will be connected to the white wire on your fan. The black wire is fan-motor switch leg and will be connected to the black wire coming from fan. The red wire is the fan-light kit switch leg and will be connected to the blue wire coming from whichever fan-light kit you may choose for your fan.

**◆Note: A licensed electrician must perform all electrical work.◆**

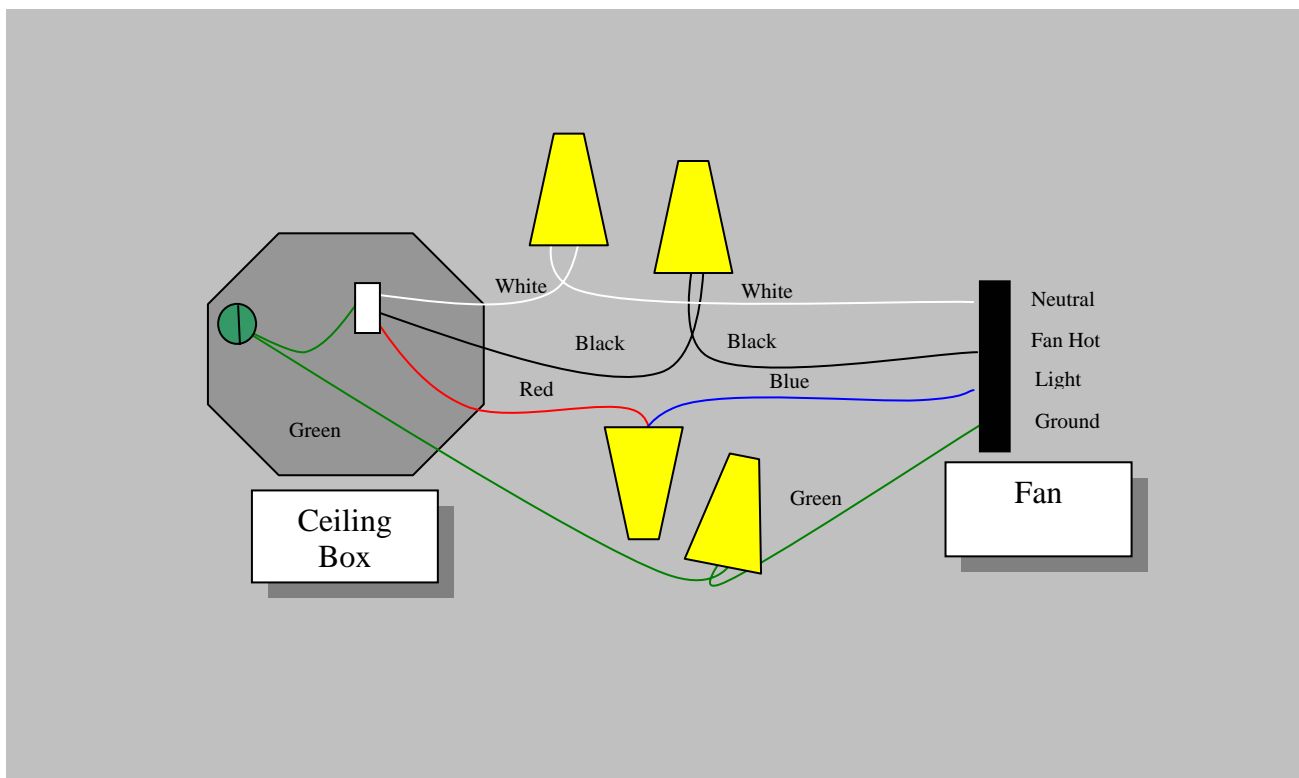

# Warranty Service

**Spartan Electric Company** strives to install the highest quality material in a professional, workmanlike manner. Like you, we know that no matter how much we try, things can go wrong.

In an effort to make your homeownership experience as enjoyable as possible, **Spartan Electric Company** warrants the entire electrical system in your home for a period of one year.

## What Is Covered:

- Electrical service equipment
- Switches and receptacles
- Door chime system (If applicable)
- Intercom system (if applicable)
- Smoke detectors
- Structured wiring system (if applicable)
- Surge protection (if applicable)
- Lighting fixtures

## What Is Not Covered:

- Light bulbs
- Reset GFIC receptacles
- Smoke detector cleaning and batteries
- Resetting circuit breakers
- Damage caused by owner negligence
- Damage caused by lightning
- Power company outages

Spartan Electric Company covers all warranted repairs at no charge during normal working hours, Monday through Friday 7:00AM to 3:30PM. For repairs outside of normal working hours, overtime fees will apply (except in emergency situations where we will be available at anytime). You can call our office at 1-800-935-0065 or e-mail us at [service@spartan-electric.com](mailto:service@spartan-electric.com).

## Typical Service Issues

In an effort to save both of us (you the homeowner and Spartan Electric Company) valuable time and money, here are a few examples of typical service issues and the steps you should take before you call to set up a service appointment. Not following these steps could result in a chargeable call if no electrical problem is found.

- 1) One of the most common issues we run into is receptacles that just stop working. A majority of the time, the most likely cause of this is due to a GFCI receptacle doing its job. If the receptacle(s) in question are in the kitchen, dining room, powder/bathrooms, exterior of the home, or in an unfinished area of the home such as garage or basement, you should:
  - A) Look at the GFCIs in the home to make sure that none have been tripped (need to have the reset button pressed back in). Reset the GFCI if “tripped”. See if problem is solved.
  - B) If this did not solve the problem you should next go to the location of your panel box. Take a look at all of the breakers and see if any are in the off position. If there are any in the off position, put them in the on position. At this point go and see if the receptacle(s) in question are operating again. No need for service at this time. If upon resetting the breaker back to the on position it immediately goes off or sparks, call for service.
  
- 2) Another issue involving receptacles not working that we get calls about are when you may find a receptacle in which only half of it works (top half or bottom half). 99% of the time this is a switched receptacle. If all of the other receptacles in the room work and only half of the receptacle in question works, follow the following steps:
  - A) Using an item you know is on and works, (lamp, vacuum, etc.) plug it into the receptacle that is not working. Look for any switches in the room and turn them to the on position. Your problem should be solved. If not, make sure there are not any switches you may have missed, and follow step “B” from issue 1 above.
  
- 3) If a receptacle or circuit loses power after you plug an item in and start using it, unplug the item and go to your panel box and reset the breaker that is off. Try plugging the item into another receptacle in a different room to see if it causes the same thing to happen. If the circuit breaker trips from the other room, the item you are using may draw too much current from the circuit that you are trying to use it on. Try using it in the kitchen or dining room receptacles, which are rated at a larger capacity than other rooms in the home.
  
- 4) If upon plugging an item in, the circuit immediately stops working and/or sparks-flames come out of the receptacle the item is plugged into, unplug the item! Go to the panel box location and try to flip on any breakers that are off. If the breaker resets to the on position, go back and plug the item into a different receptacle in a different room. If the circuit goes off the same or similar way, unplug it and go reset the breaker. Try and plug a different item into the receptacle(s) that caused the circuit to trip. If the different item works and nothing goes off, the original item used is most likely defective and caused the problem. You may feel the need to call us for service at this point to make sure that there hasn't been any damage done to the wiring and there isn't any latent danger from the incident. Please note that this may be a chargeable service call.

## Typical Service Issues continued

- 5) If you have an outside lamppost that has stopped working, you should first check that the bulb has not blown out. If the bulb is not bad, check that the switch that controls the post (if applicable) has not inadvertently been turned to the off position. If this didn't solve the problem you will then want to find any GFCI receptacles that may be tripped and reset them. The GFCI that controls this will most likely be in one of three places: garage, unfinished basement, or mechanical room. If upon doing all of the above the problem isn't solved, call and set up a service appointment.
- 6) If the outside lamppost goes on at dusk and off at daybreak by itself, it is controlled by a photocell. If the lamppost stops going off and stays on at all hours, the photocell has gone bad. You should call to set up a service appointment.
- 7) The first thing you should do when a light fixture has stopped working is to put a bulb that you know is good into the fixture to make sure that it isn't just a bad bulb. You would be surprised to hear how many light bulbs are bad even when you get one out of a brand new package. If upon trying at least two (2) different bulbs the fixture will not work and you have tried turning the switch on and off, call to set up a service appointment.

These are just a few of the more common issues that seem to come up from time to time. In a majority of cases, by following the above guidelines in these types of situations you may be able to save yourself from making a service appointment that will cost you time and money if nothing is found to be wrong with the wiring or device(s) in question. If you have any questions or concerns about a problem in your new home's wiring, feel free to call our Service Manager at: **(800) 935-0065**. They will take all of your information, ask you if you have followed the above steps, and be able to help you with any questions you may have.

# OnQ Structured Wiring Systems

**The OnQ Home Wiring System has three main components:**

**The Service Center.** This is where services from outside the house (cable TV, telephone, DSS satellite, internet, etc.) enter the home. This central hub distributes these services to locations throughout the house - similar to the electrical breaker panel.

**High-Performance Cables.** Just because all of these services can reach your house, it doesn't mean that you can access them. Certain services like digital satellite, high-speed internet, digital phone, and digital TV require high-performance cables.

The OnQ system includes *RG-6 quad-shielded coax* for TV and video and *Category 5E cable* for telephone and data. Quad-shielded means you have maximum protection from interference with your TV picture. Category 5E cable provides high-speed access to four phone lines without crosstalk. These cables deliver all the performance you need today, while providing the capacity to handle tomorrow's technology.

**Outlets.** The outlets in each room determine which services are available in that room. Without the proper outlets, the high-performance wiring behind the walls is of little value.

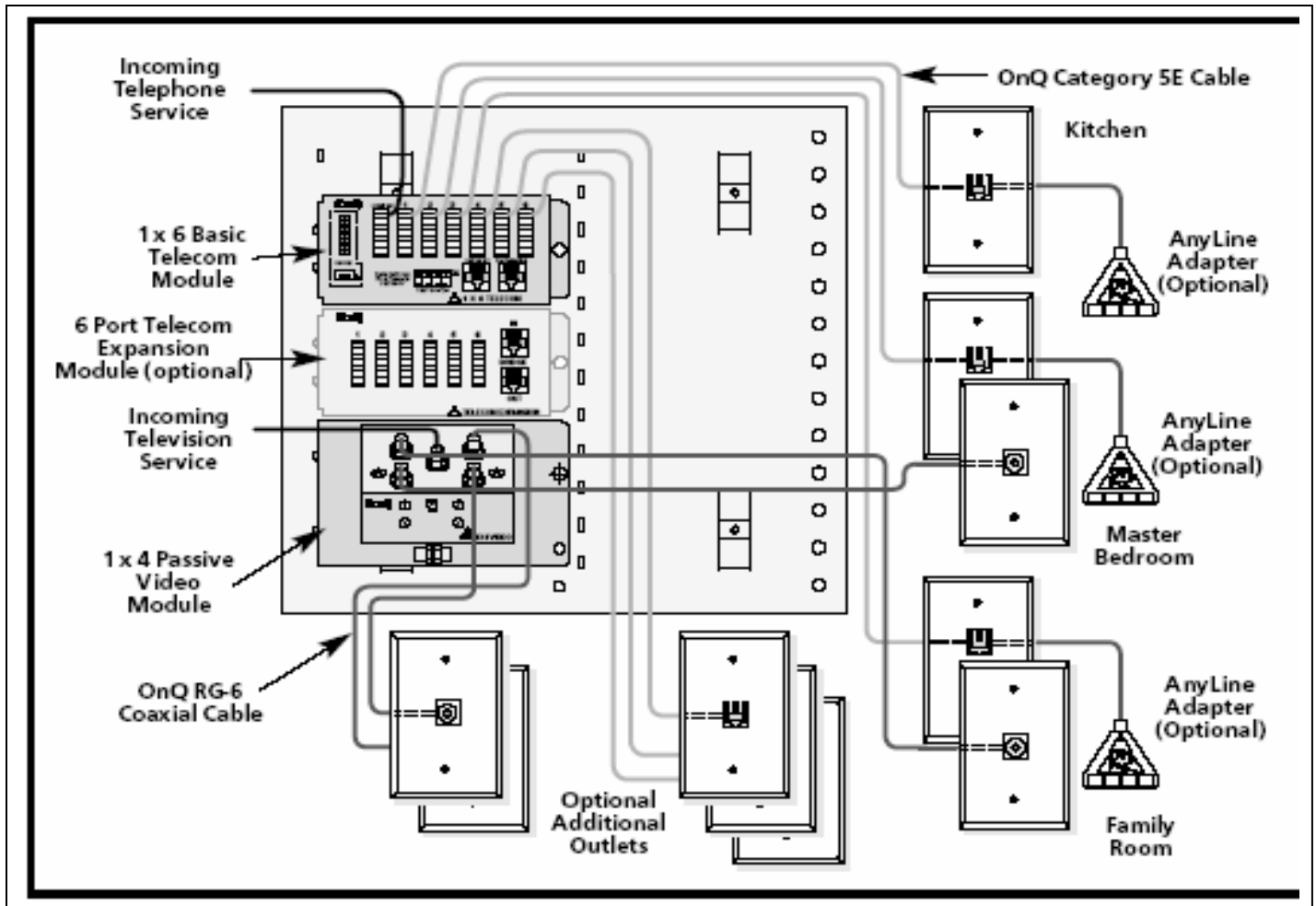



- OnQ Service Center
- OnQ Video Module
- OnQ Telecom Module
- Network Interface Module \*
- High-Performance OnQ Cabling
- OnQ Outlets

## Base Package

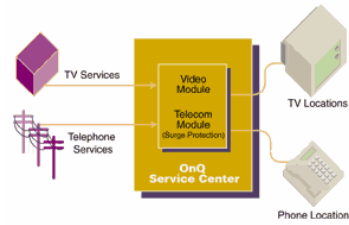

\* This module is included as a way of terminating the all of the conductors in the High-Performance cabling. **In the base package the network will not operate.** An upgrade package will need to be purchased like the Home Office or Home Network system as an example that will provide an operational network environment by way of additional equipment that will be installed.

The listed items above are what come in the standard package for the base On-Q system. Your installation can be customized by purchasing upgrades to the installation that are listed below. These upgrades could include any of the following but are not limited to them. By clicking on the On-Q Home logo above, or the upgrade title you can be taken to the On-Q site and see more information about each option.

## Home Entertainment Upgrade

The *OnQ Home Entertainment Upgrade* puts you in control of selecting the types of services you want today and the flexibility to change at a later time. This option even allows you to turn your TV into an integral part of your home security network. For instance, you could add a front door security camera to see who's at the front door from any TV in your home.

- Enhanced video module
- Two-way amplifier for sharp, clear pictures and video distribution
- High-performance cabling for digital satellite and high-definition TV
- Connections for Internet TV, DSS satellite, cable TV, or local antenna
- Front door camera wiring

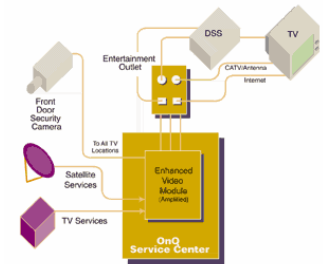

## Home Office/ Education Center

Home businesses, satellite classes, and all that work that didn't get done at the office require access to more than a plain old telephone line. The *OnQ Home Office/Education Center* is the perfect way to bring these capabilities to your home office or children's study area.

- High-performance, high-speed cabling (Category 5)
- Enhanced telecommunications module
- Dedicated data terminal outlet
- Built-in surge protection for all phone lines
- Home Office Outlet: two phones (home/business, fax), cable modem/TV, and digital internet connection

You'll be able to work from home with the same technology you use at the office.

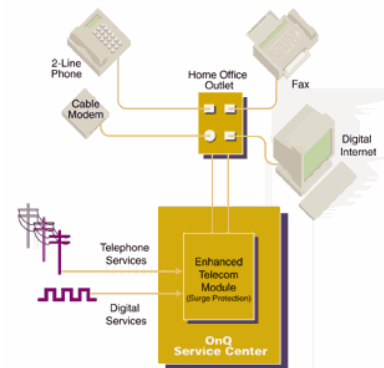

# Home Network System

Continuous ultra-high-speed internet service is a reality today. Your **OnQ Home Network System** will make this service available at the same time in multiple locations. Additionally, the network allows you to share files, modems, and printers inside your home.

- Four-port 10Base-T Ethernet hub
- High-performance, high-speed cabling (Category 5)
- Four computer outlet locations

Additional Modules may be necessary.

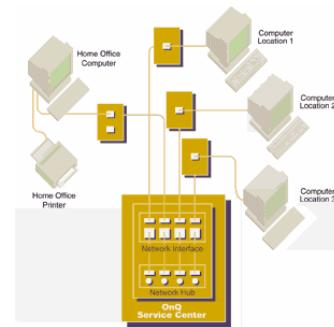

# Wireless Dimming System

**LUTRON** THE WORLD LEADER IN LIGHTING CONTROL SINCE 1961



RadioRa® is a wireless whole house lighting control system that can be installed in any home quickly and easily.

By simply replacing existing switches with RadioRa® dimmers you can monitor and control lighting throughout your home from any convenient location, including your car or office.

For complete details and options toll free 1-800-935-0065.

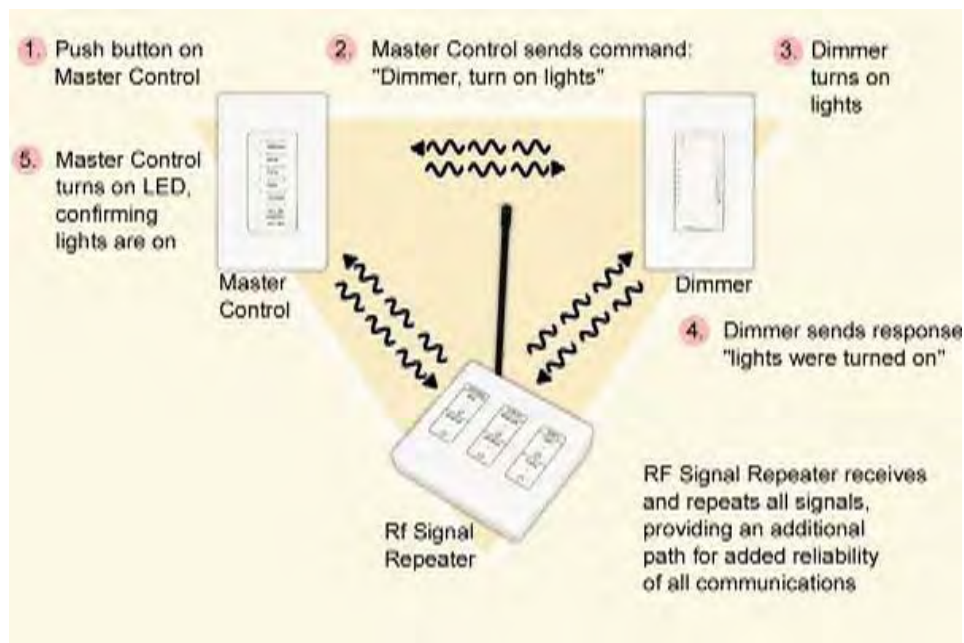

## Car Visor Control Transmitter



- Provides control of home lighting from the car--turn lights on as you arrive, and off as you leave
- Provides control of garage doors and gates
- Clips conveniently to your car's sun visor
- Use with the Multi-Function Entry Master Control (RAMC-MFE-)
- Model # RA-VCTX-

# Residential Emergency Home Standby:

Generac Power Systems, Inc. manufactures a complete line of emergency automatic home standby generators that can be installed during new construction or retrofitted into existing residences and businesses. Residential emergency home standby generators are

permanently installed outside (similar to an air-conditioning unit), supply electrical power to all pre-selected lights and appliances, and are powered by either natural gas or LPG. Models range from 7,000 to 40,000 watts. They work with a matched automatic transfer switch that responds within seconds when utility power shuts down, even when no one is home!

Generac is truly a vertically integrated manufacturer. From the core of the engine to the controls, we design and build our complete product. This is precisely why we stand so strongly behind it with one of the best warranties in the industry. With intensive control over our engineering through manufacturing, we're able to ensure that our products are quiet, powerful and reliable.

Generac Power Systems' consumer products are renowned for value, reliability, and long life. Our residential emergency standby generators are the #1 choice for homes and small businesses. Our portable generators are the obvious choice for industrial, commercial and residential where extreme use and maximum horsepower is required. Our revolutionary OHVI™ industrial



engines utilize the most advanced technology and automotive design to provide unparalleled engine life and performance. OHVI is the heart of our home standby generators as well as our Impact™, Primepact™, and Quietpact™ generators for the recreational vehicle market, and is destined to be the engine of choice for all outdoor power equipment.

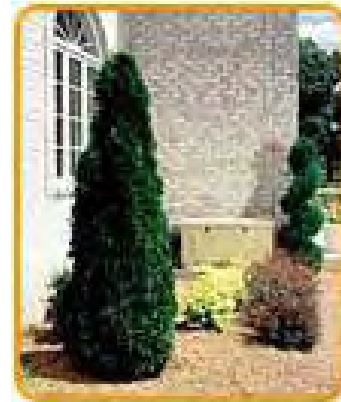

**Spartan Electric Company** is an authorized dealer of Generac Power Systems, with factory-trained technicians ready to provide you with expert installation and service. For more information call toll free 1-800-935-0065.

# Ceiling Fans and Accessories

Spartan Electric Company's vast buying power affords us to provide you with the best products available. These are some of the few paddle fan manufacturers we can provide:

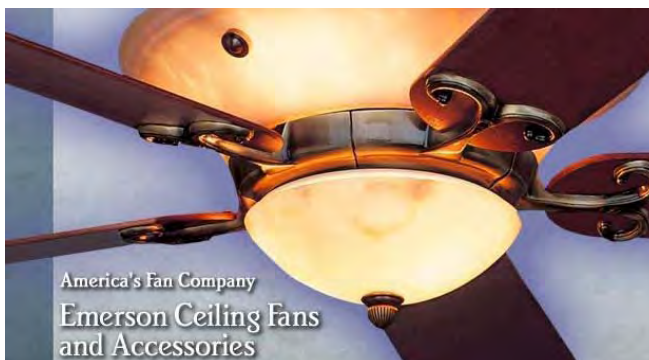

# Intercom Options



*Integrated Home Technologies*



Now you can fill your home or patio with more than seven hours of music from your favorite CDs without reloading. This is the only completely built-in multi-CD player on the market featuring a pullout magazine that holds up to six discs. You can even keep extra magazines handy for virtually endless hours of uninterrupted play.

Imagine every feature you would want in a high-end CD player. The DMC1 offers all these features and more, including remote control track selection from room stations and an optional RF hand-held remote control that allows you to direct most major functions from anywhere in your home.



You can't be everywhere at once – even in your own home. But with an M&S communication system, you can hear what's going on anywhere in your home. A baby's cry, a child's call – you hear it instantly and can respond just that fast. An M&S communication system also means that your family can hear you – call them to dinner, tell the kids to keep it down. An M&S communication system lets you do all this, too – without having to chase everyone down. Now that's convenience.

# Whole House Surge Protection



## Surge Protection Devices and Transient Voltage Surge Suppressors (TVSS)

### SURGEBREAKER™ PLUS Multi-Path Surge Protector



This exclusive Square D whole-house surge protector installs externally to any load center, providing comprehensive protection for telephone wiring, coax cable, and ac branch circuit wiring. The SURGEBREAKER PLUS Multi-Path Surge Protector also comes with a 5-year, \$50,000 warranty for residential applications. Coverage includes appliances and electronics, including computers. We also recommend using the Square D SURGEBREAKER™ Secondary Surge Arrester as a valuable second line of defense.

- Rated for protection up to 60,000 amps
- Solid state design protects 120/240V circuits
- Meets UL 1449 Second Edition standards

# Miscellaneous Electrical Options

This is just a small list of some things you may be unaware of at the time you are purchasing your new home. It is a very busy time for you, but there are a few things you should think about before it is too late. Below are a few examples of some options you may need for certain things, and some of the services we can supply to you after you have moved into your home.

## **OPTIONS: For the rough-in stage.**

Do you have a piece of equipment that you will be using that needs power? If so, you should make sure that the area into which you want to place it in the home has the correct type of circuit and or receptacle to plug the item into. This could include any of the following items:

- I. Freezer
- II. Second refrigerator
- III. Computer equipment (May also need to have a network location or even a standard phone for internet access along with a plug and possibly a circuit)
- IV. Home Stereo / Home Theater equipment (We offer a full line of products that can give you Whole House Audio.)
- V. Work area for any tools (ex: For possible craft, or wood working area)

## **OPTIONS: For after you've moved in.**

After you have lived in the home for a period of time you may have the need for an electrical contractor. We provide a full line of services to you that can include but is not limited to the following:

- I. Wiring for rooms you may be finishing (rec. rooms, dens, bathrooms, basements, etc.)
- II. Wiring for additions (garages, sunrooms, workshops, etc.)
- III. Hot Tub / Spa wiring
- IV. Pool wiring
- V. Any type of remodeling project
- VI. Adding receptacles, switches, light fixtures
- VII. Changing out light fixtures

These again are only a few things that we may be able to help you with if the need arises. Feel free to call us for an estimate for any electrical project you may have Toll Free at **(800) 935-0065**, or check us out on the web at [www.Spartan-Electric.com](http://www.Spartan-Electric.com). All of our estimates are free of charge.